

D24 W Water Heater

Installation
Troubleshooting &
Parts Manual



For Heater Models

CA 1869 25 - includes coolant pump
CA 1869 20 - without coolant pump

November 1998

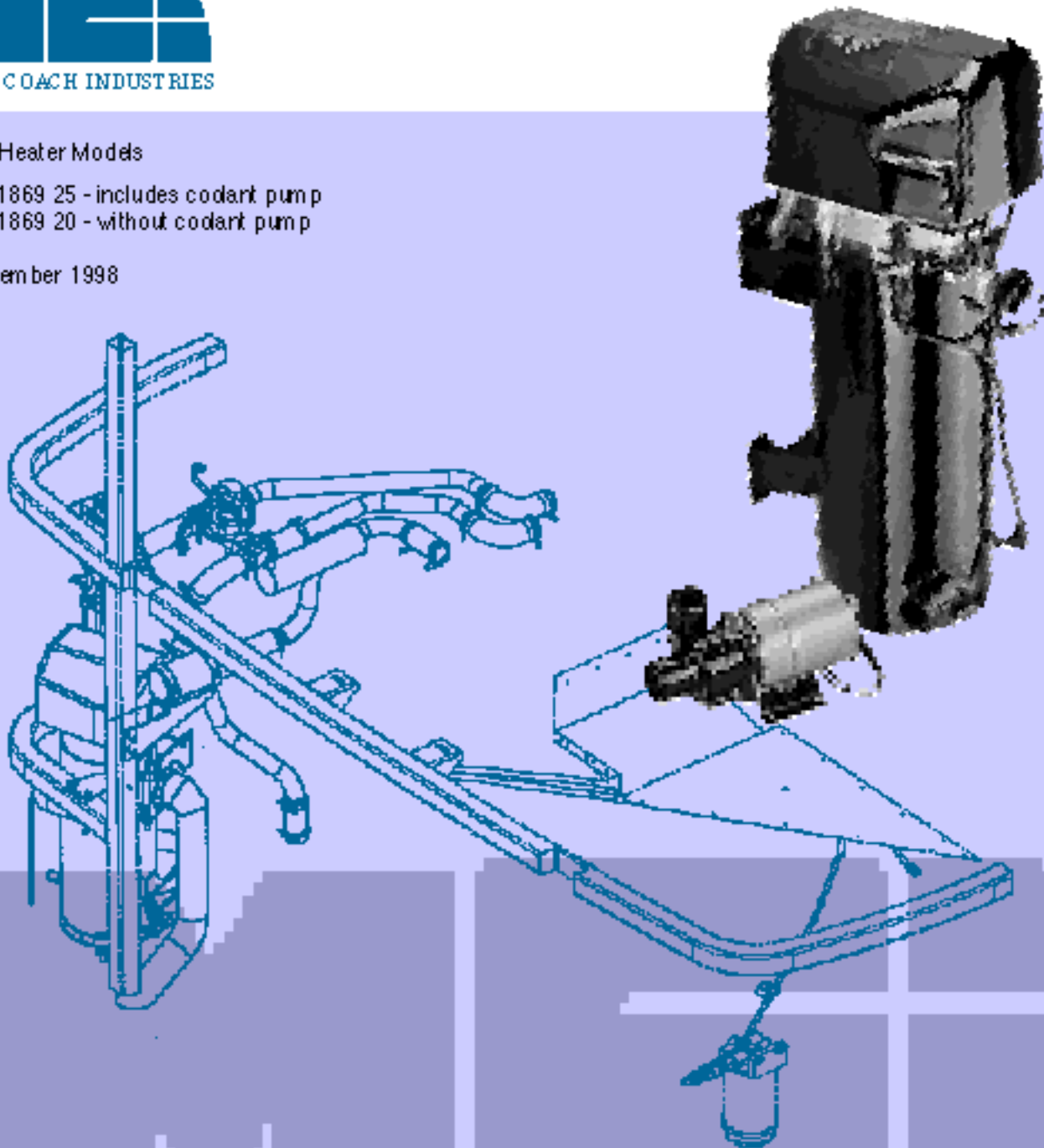

MOTOR COACH INDUSTRIES

Table of Contents

I. Introduction	<ol style="list-style-type: none">1. Heater Warnings2. Introduction3. Specifications4. Heater Components5. Principal Dimensions	Page 1-5
II. Installation Procedures	<ol style="list-style-type: none">1. Heater Location2. Heater Mounting3. Heater Plumbing4. Fuel System5. Electrical Connections6. Exhaust Connections	Page 5-10
III. Heater Operation	<ol style="list-style-type: none">1. Pre-Start Procedures2. Start-Up3. Running4. Switching Off5. Safety Equipment6. Operational Flow Chart7. Wiring Diagram Model # 25 1869 01/05	Page 10-13
IV. Maintenance, Troubleshooting & Repairs	<ol style="list-style-type: none">1. Recommended Periodic Maintenance2. Troubleshooting3. Fuel Quantity Test4. Adjusting the combustion air5. Dismantling the water pump6. Repair Steps	Page 14-24
VII. Heater Components	<ol style="list-style-type: none">1. Parts Diagram2. Description & Part #'s	Page 25-29

Special Notes

Note: Highlight areas requiring special attention or clarification.

Caution: Indicates that personal injury or damage to equipment may occur unless specific guidelines are followed.



Warning: Indicates that serious or fatal injury may result if specific guidelines are not followed.



1. Heater Warnings

Warning To Installer

- Correct installation of this heater is necessary to ensure safe and proper operation. Read and understand this manual before attempting to install the heater. **Failure to follow all these instructions could cause serious or fatal injury**

Warning - Explosion Hazard

- Heater must be turned off while re-fueling.
- Do not install heater in enclosed areas where combustible fumes may be present.
- Do not install heaters in engine compartments of gasoline powered boats.

Warning - Fire Hazard

- Install the exhaust system so it will maintain a minimum distance of 2" from any flammable or heat sensitive material.
- Ensure that the fuel system is intact and there are no leaks.

Warning - Asphyxiation Hazard

- Route the heater exhaust so that exhaust fumes cannot enter any passenger compartments.
- If running exhaust components through an enclosed compartment, ensure that it is vented to the outside.

Warning - Safety Hazard on Coolant Heaters Used With Improper Antifreeze Mixtures

- The use of Espar coolant heaters requires that the coolant in the system to be heated contain a proper mixture of water and antifreeze to prevent coolant from freezing or slushing.
- If the coolant becomes slushy or frozen, the heater's coolant pump cannot move the coolant causing a blockage of the circulating system. Once this occurs, pressure will build up rapidly in the heater and the coolant hose will either burst or blow off at the connection point to the heater.
- This situation could cause engine damage and/or personal injury. Extreme care should be taken to ensure a proper mixture of water and antifreeze is used in the coolant system.
- Refer to the engine manufacturer's or coolant manufacturer's recommendations for your specific requirements.

Note: During electrical welding work on the vehicle disconnect the power to the heater in order to protect the control unit.

2. Introduction

Quality engineered to provide a dependable means of heating, the Espar D24W is a diesel fired coolant heaters capable of putting out 82,000BTU's (24kW).

The heater pumps coolant from the engine, heats it and returns it to the engine. By routing the hot coolant through heat exchangers it is also possible to heat the interior of the vehicle. It is also possible to route the coolant through stainless steel tubing to pre-heat hydraulic fluid and fuel in off-road applications.

Since the heater runs on diesel fuel and 24 volt power, it is able to perform this completely independently of the vehicle engine. A temperature regulating switch in the unit regulates the coolant temperature between a low of 149°F (65°C) and a high of 176°F (80°C) by automatically cycling the heater.

The D24W can be operated from the vehicle cab by an on/off switch, a preselect timer or a combination of both.

Temperature regulating and overheat shut down switches are among the safety features which make the D24W a safe and dependable heating system.

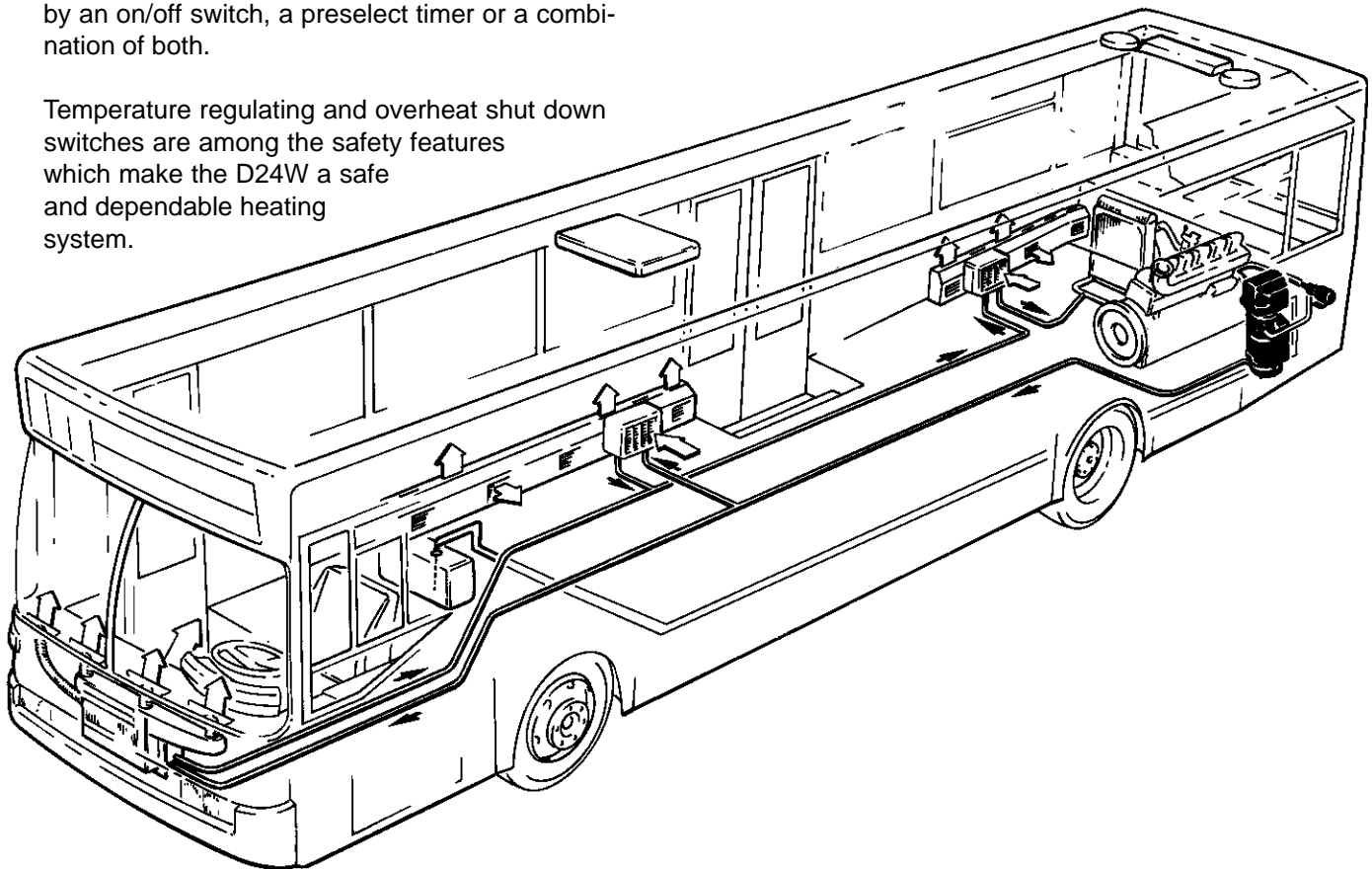



3. Specifications D24W - Vertical Installation "E" Coach

Model (24V)	D24W
Heat output ($\pm 10\%$)	82,000 BTU (24Kw)
Current draw ($\pm 10\%$) (without water pump)	5 amps
Fuel consumption ($\pm 10\%$)	2.90 l/hr (0.76 gal/hr)
Operating Voltage Range	
Minimum Voltage	20V
Maximum Voltage	28V
Working pressure (coolant)	0.4 - 2.0 bar 6-29 psi
Water capacity	2.6 l (0.686 gal)
Ambient temperature (minimum)	-40°C to +70° C -40°F to 158°F
Overheat temperature Shutdown ($\pm 5\%$)	
Stage 1	195°F (90°C)
Stage 2	221°F (105°C)
Weight	55 lbs. (25 kg.)
Controls available	Driver and HVAC system
Specifications - water pump	Standard
Voltage	24 V \pm 20%
Current draw	4.6 amps
Water throughput	5000 l/hr @ 200mbar 1320gal/hr @ 200mbar

Note: The heater is equipped with a high voltage cutout as well a low voltage cutout.

4. Heater Components

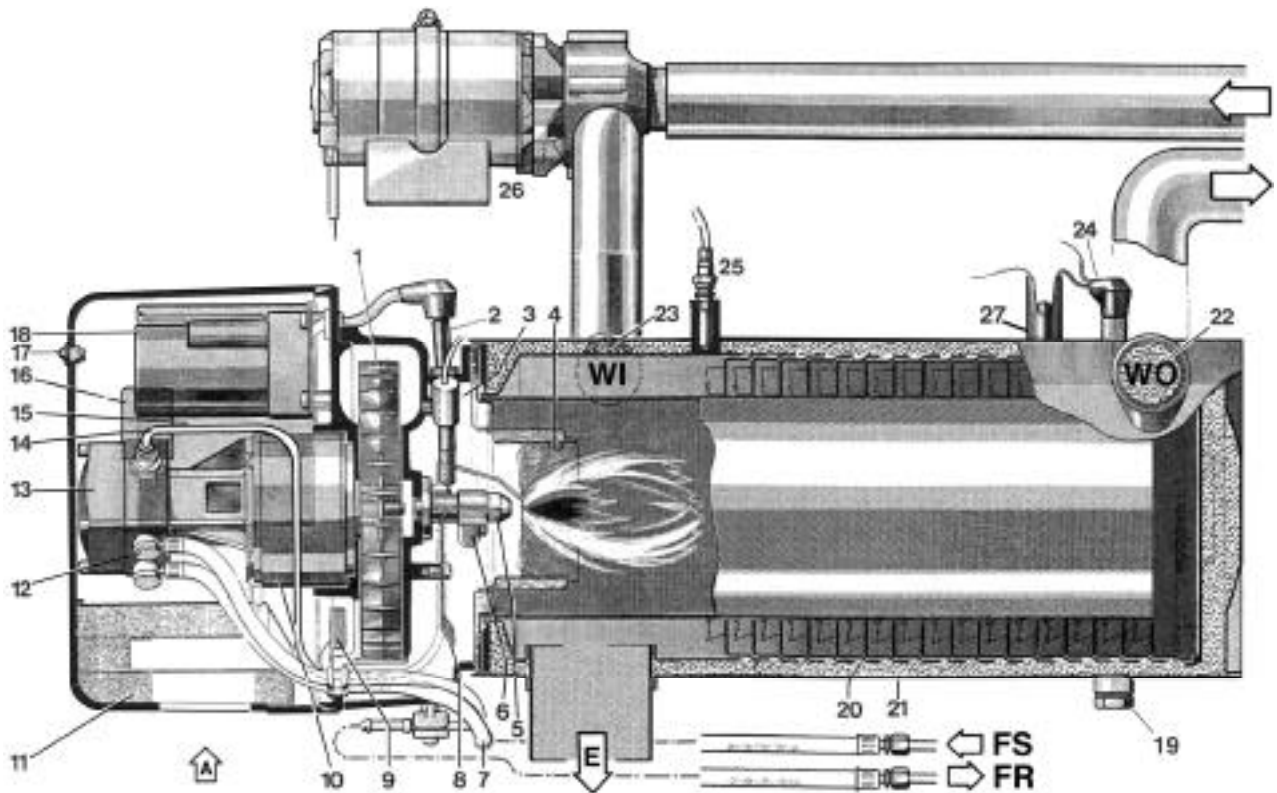

A = Combustion air
E = Exhaust
F = Fuel supply line
FR = Fuel return line
WO = Water Outlet
WI = Water Inlet

- | | | | |
|----|------------------------------------|----|------------------------------------|
| 1 | Combustion air blower wheel | 16 | Fuel solenoid valve |
| 2 | Ignition electrode | 17 | Diagnostics display |
| 3 | Flame monitor | 18 | Ignition spark generator |
| 4 | Mixing head | 19 | Bleed plug |
| 5 | Fuel nozzle | 20 | Heat exchanger with flame pipe |
| 6 | Fuel nozzle pre heating (optional) | 21 | Outer casing |
| 7 | Fuel line | 22 | Water connection socket - outlet |
| 8 | Air baffle plate | 23 | Water connection socket - inlet |
| 9 | Combustion air control plate | 24 | Safety thermal melt fuse |
| 10 | Electric motor | 25 | Temperature probe |
| 11 | Silencer | 26 | Water pump |
| 12 | Fuel connection | 27 | Automatic reset overheating switch |
| 13 | Fuel pump | | |
| 14 | Internal fuel line | | |
| 15 | Control unit | | |



5. Principal Dimensions

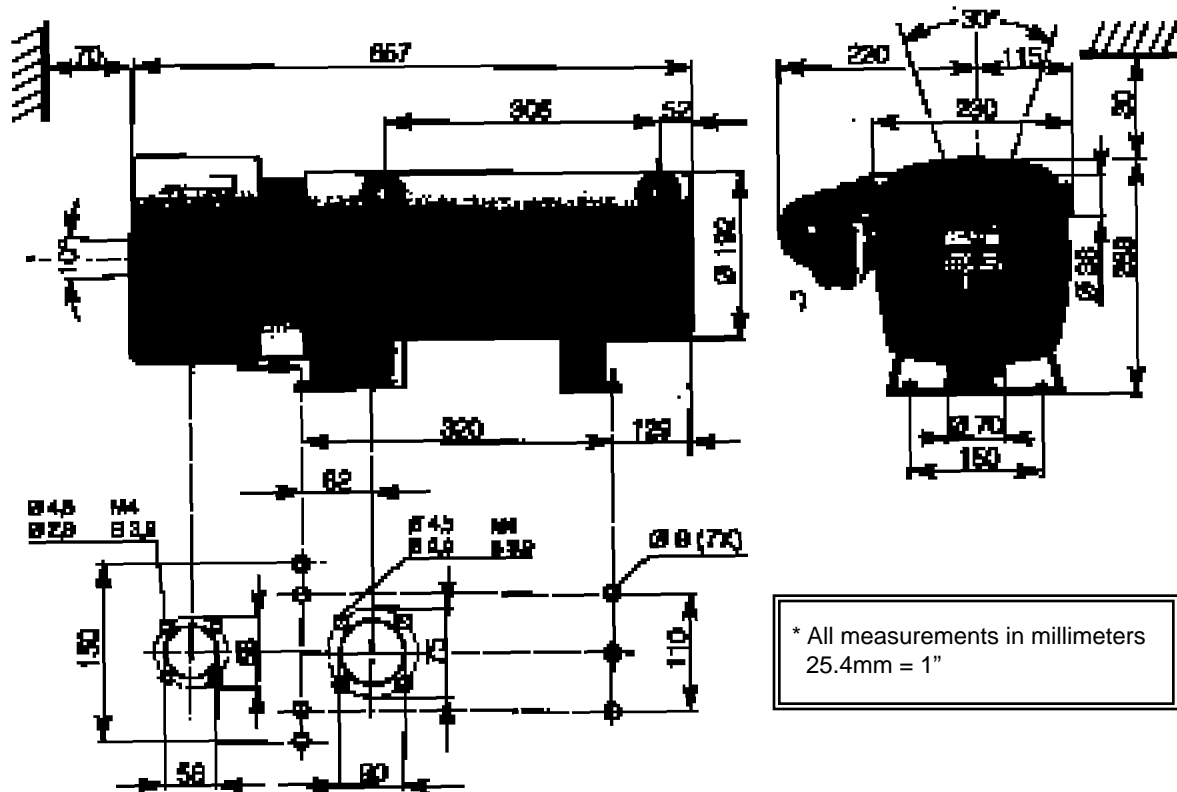

II. Installation Procedures

1. Heater Location

Mount the heater in a protected area eg: storage compartment or engine compartments. When mounting the heater adhere to the following conditions:

- Situate the heater below the normal coolant level of the engine.
- Guard against excessive road spray.
- Keep coolant hoses, fuel lines and electrical wiring as short as possible (see fuel line & electrical wiring specs on following pages).

2. Heater Mounting

MCI custom mounted. Rear of the vehicle

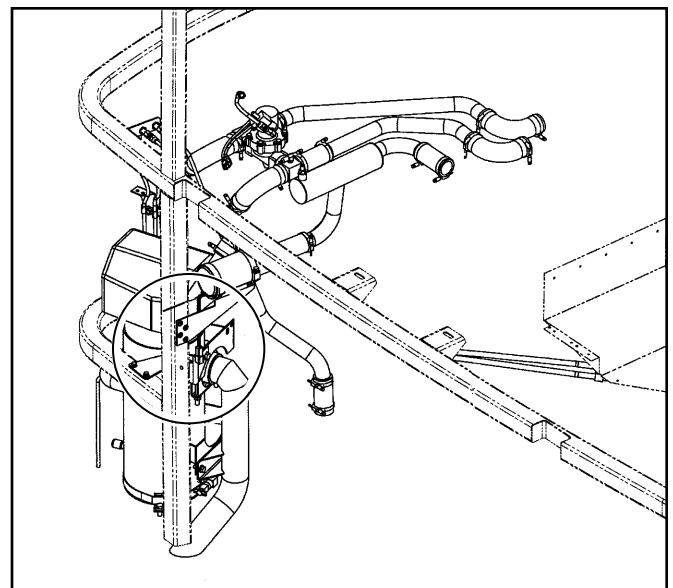

3. Heater Plumbing

The heater can be incorporated into the engines cooling system for engine preheating and can provide supplementary space heat for passenger comfort.

Engine Plumbing

To pre heat engines, follow these guidelines and refer to engine plumbing diagram shown below.

- Install fittings into the block for pick up and returns.
- Use existing holes in the engine block (ie. remove blanking plugs when possible).
- Use shut off valves to ensure the system can be isolated from the engine when not in use.
- Provide 1.5" (37.5mm) hose barbs for hose connections.
- Use (1.5" (37.5mm) hoses to ensure adequate coolant flow.

Note: The coolant must contain a minimum of 10% antifreeze at all times as a protection against corrosion. Fresh water will corrode internal heater parts.

- | | |
|---|----------------|
| 1 | Heater |
| 2 | Water pump |
| 3 | Shut-off valve |
| 4 | Engine |
| 5 | Radiator |
| 6 | Heat Exchanger |

- Keep the pick up and return points as far apart as possible to ensure good heat distribution.
- Take the coolant from a low point on the engine to reduce aeration in the system.
- Ensure proper direction of coolant flow by taking coolant from a high pressure point in the engine and returning it to a low pressure point. (ie. pickup from back of block and return to the suction side of the engine's water pump).
- Ensure adequate flow rate through the heater by comparing the incoming and outgoing coolant temperatures. If the rise in temperature exceeds 18°F (10°C), coolant flow must be increased by modifying the plumbing.
- Ensure the heater and water pump are installed as low as possible to allow the purging of air.
- See plumbing diagrams for alternative plumbing methods.

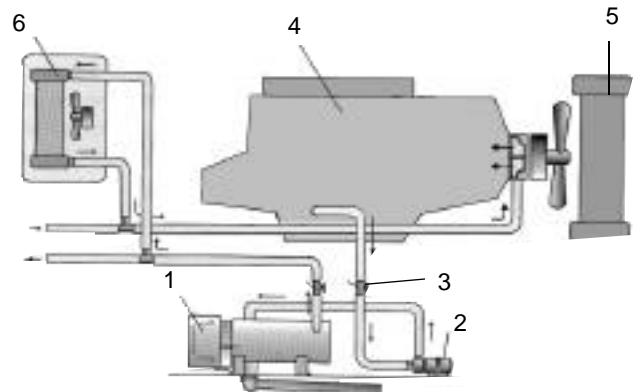

D24W / D30W plumbed with heat exchanger

Adding Heat Exchangers

- Maintain proper flow through heater at all times
- Provide air relief cocks at the heat exchanger.
- If the water piping cannot be run with a continuous rise to the heat exchangers, provide air relief cocks at high points.
- Connect plumbing circuits in parallel to avoid reduction of plumbing hose size and avoid restriction of flow.
- Ensure thermostat and flow control valves do not completely close off flow through heater
- Refer to plumbing diagrams for examples

Warning: Ensure that a coolant flow path is open at all times while the heater is operating to avoid overheating conditions. Failure to do so may result in bursting of coolant hoses with the release of hot coolant and steam



Bus Plumbing Diagram

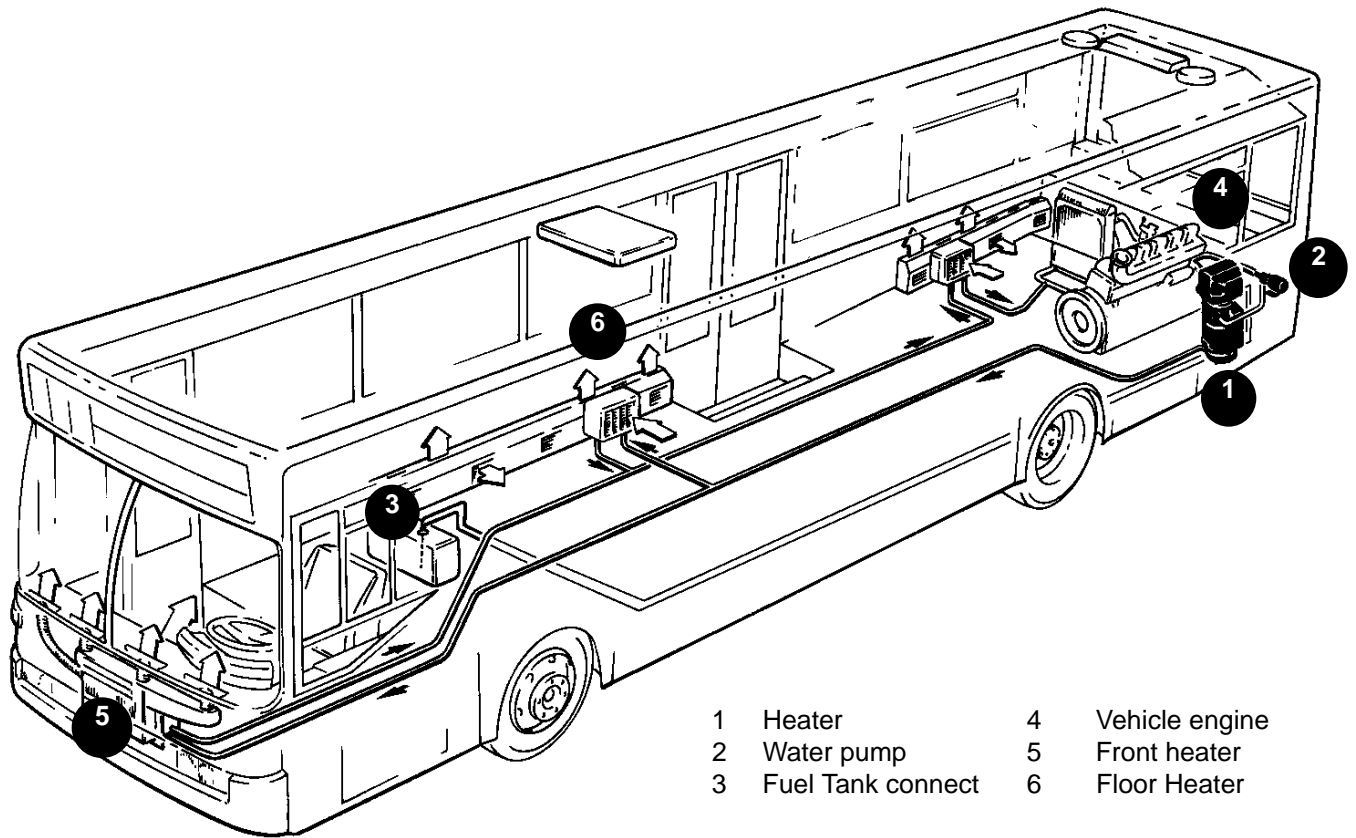

4. Fuel System

To connect the fuel supply to the heater (at the fuel filter), a supply line and a return line to the tank are necessary. To accommodate these lines at the tank, a fuel pick-up pipe with a return stem is available. The fuel filter is located into the feed line near the heater. It is recommended that a shut off valve be fitted near the heater on both the intake and return lines. (fuel filter and shut off valves are already attached to the heater in the compact version). Refer to Figures below for connections and specifications.

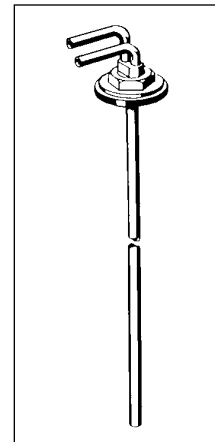

Fuel pick up pipe with return

Fuel System Tolerances

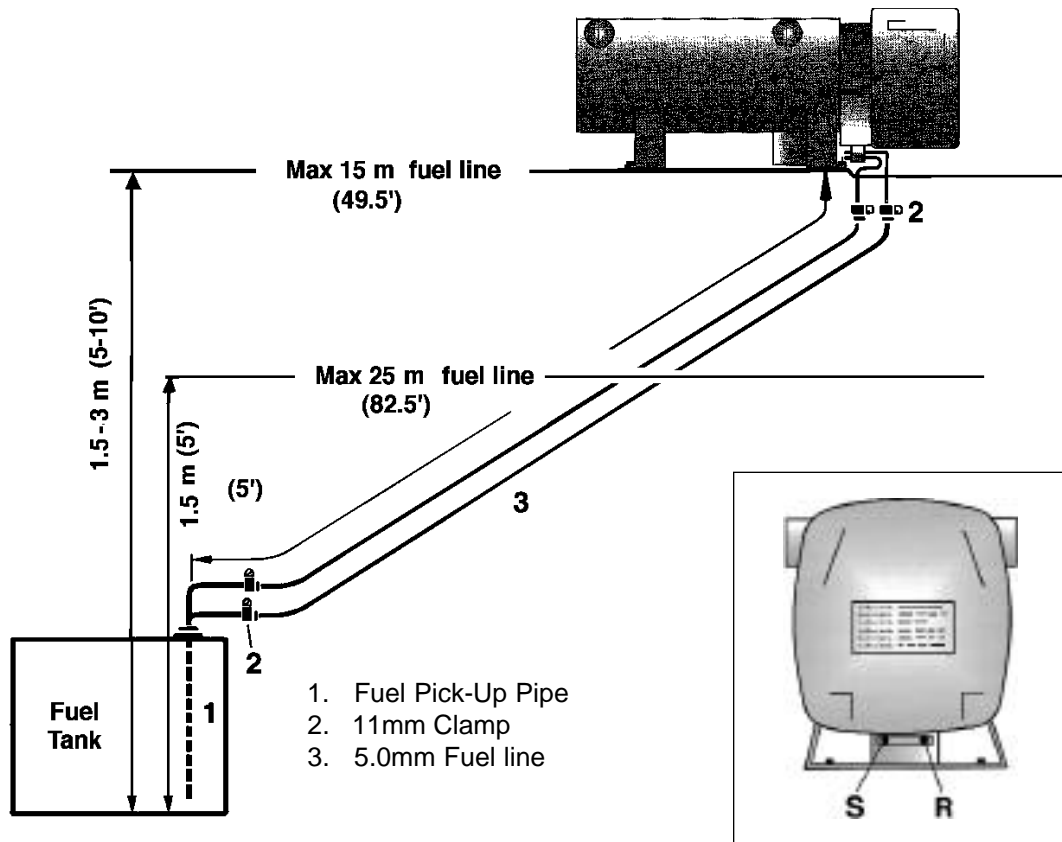

S = Fuel Supply
R = Return fuel

If the D24W / D30W heater is situated within 1.5 m (5') above the fuel tank, a permissible 25 meters (82.5') of fuel line can be used.

If it is between 5 - 10' (1.5 - 3 m) above the fuel tank a maximum fuel line of 15 m (48.5') is permissible.

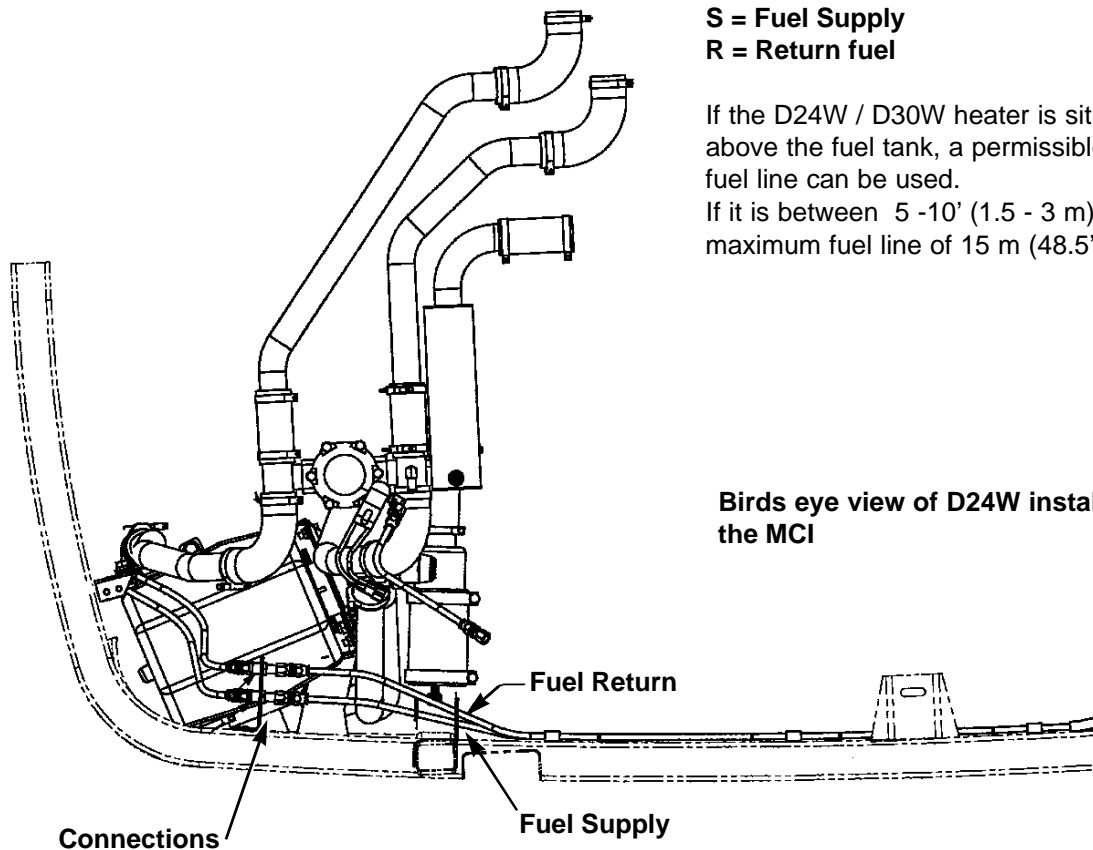

Birds eye view of D24W install on the MCI



5. Electrical Connections

Caution: To avoid potential short circuit damage during installation, make connection to the positive terminal at battery after all electrical connections are complete.

- A. Power/ Pump Harness**
 - 3 core harness (red, red, brown).
 - Connect red wires to vehicle battery (+) via fuse link provided, using ring terminal provided.
 - Connect brown wire to vehicle battery (-) using ring terminal provided.
- B. Switch Harness**
 - 3 core harness (red, brown, yellow).
 - Run to location of switch.
 - MCI uses Drivers panel HVAC control
- C. Main Heater Harness**
 - Connects the above harnesses to control unit and other components inside the heater cover.

MCI using Deutch connectors

See parts section on page 28 for connector type.

Compact version

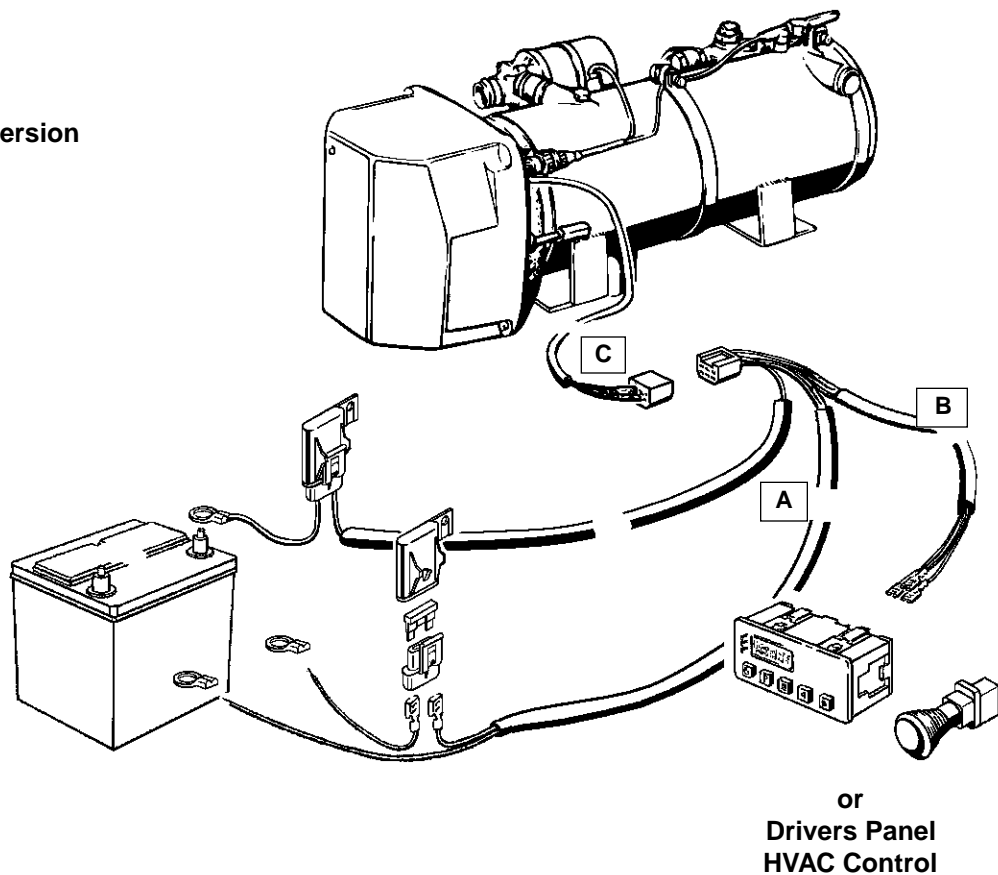

Note: All harnesses should be cut to length.
All exposed electrical connections should be coated with protective grease.

6. Exhaust Connection

A 2.8" (70 mm) flexible tube exhaust pipe with a length no more than 4m long is required for the exhaust. A 3" (75mm) muffler clamp is needed to secure the exhaust to the the heater. Connect the exhaust as follows:

- Connect the exhaust pipe to the exhaust tube on the heater and attach with clamp provided.
- Run exhaust to an open area to the rear or side of the vehicle so that fumes can not build up and enter the passenger compartment or the heater combustion air intake.

- Install exhaust pipe with a slight slope or drill a small hole in the lowest point to allow water to run off. Any restriction in exhaust will cause operational problems.
- Secure the exhaust pipe at the heater using clamps and holders. Secure the exhaust pipe externally using clamps and holders.

Caution: Run exhaust so that it cannot be plugged by dirt, water or snow.

Ensure the outlet does not face into the vehicle slip stream.

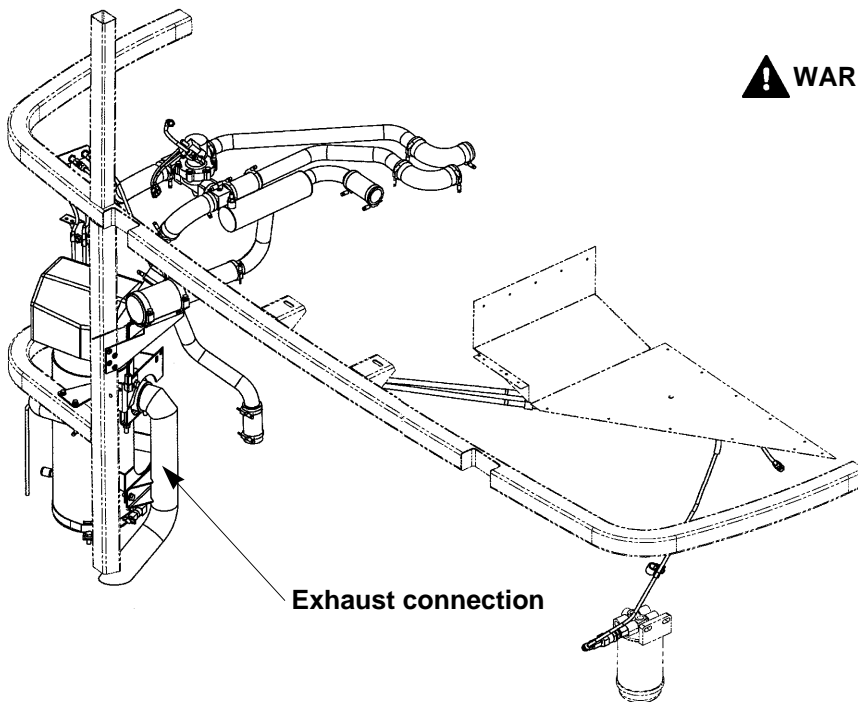

Exhaust connection

MCI supplies there own exhaust

! WARNING: The exhaust is hot, keep a minimum of 2" clearance from any heat sensitive material. Route exhaust so that the exhaust fumes cannot enter the passenger compartment.

III. Heater Operation

Drivers manual control always works.

HVAC control turns heater "on" only if the main temperature controller (for interior heat) calls for "full" heat for more than 1 minute.

Note: In the summer months the main temperature controller may not call for full heat due to high interior temperatures. The heater may not start with engine running in warm summer weather.



1. Pre-Start Procedures

Upon completion of installation prepare the heater as follows:

- Check all fuel, electrical and plumbing connections.
- Refill the engine coolant
- Bleed air from the coolant system by loosening the locking screw on the coolant inlet barb.
- Re-tighten screw
- Run engine to further bleed the system.
- Top up engine coolant.

2. Start Up

Once switched on the following sequence occurs:

- Control unit does a systems check (flame sensor, temperature, safety thermal cutout fuse and various other control unit checks).
- Water pump starts circulating coolant fluid.
- Electric motor starts the combustion air blower and fuel pump.
- A motor system test is performed and the electric motor is shut off while the control unit measures the generated voltage.
- Fuel solenoid opens enabling fuel to be sprayed into the combustion chamber.
- Atomized fuel is then ignited by a high voltage ignition spark.
- Once ignition takes place a photoresistive cell automatically switches the ignition system off (ignition time: 10 seconds maximum).

3. Running

Once ignition is successful the following operations take place:

- Heater runs in full heat mode and the temperature is monitored at the heat exchanger.
- If the temperature rises above 80°C(176°F) the heater automatically switches itself off.
- The water pump continues to circulate coolant to allow the heater to monitor engine temperature.
- When the temperature drops below 65°C(149°F) the heater will cycle itself back on automatically.
- The heater continues to run as described above until it is switched off, either manually, automatically by a timer or heater malfunction shutdown.
- The set value of the water temperature is adjusted in the control unit. If a temperature reducer is connected the control temperature is reduced by approx. 8°C. (see wiring diagram)

4. Switching Off

- When the heater is switched off the fuel solenoid valve closes, shutting off the fuel supply.
- The flame is extinguished and a switch off lag time begins. (2 1/2-3min.)
- The combustion air blower and water pump continue to run for a three minute cool down cycle clearing residual combustion gases and drawing heat off the heat exchanger preventing any local overheating.
- After the three minute cool down the heater shuts off.

Note: If the heater fails to start the first time it will automatically attempt a second start. If unsuccessful the heater will shut down completely.

Note: On initial start up the heater may require several start attempts to self prime the fuel system.







Note: During operation the heater continually senses the input voltage from the batteries, if the input voltage drops to approximately 20 volts or rises above 30 volts the heater will automatically shut down.

5. Safety Equipment

The control unit, overheat switch and flame sensor (photoresistive cell) continually monitor heater functions and will shut down the heater in case of a malfunction.

- The control unit ensures electrical circuits (fuel pump, combustion air blower etc.) are complete prior to starting the heater.
- If the heater fails to ignite within 10 seconds of the fuel solenoid opening, a “no start safety shutdown” follows.
- If the heater flames out during operation, the heater automatically attempts to restart. If the heater fails to ignite within 10 seconds of fuel delivery, or ignites but flames out again within 3 minutes, “flame out” shutdown follows.
- Overheating due to lack of water, a restriction or a poorly bled coolant system results in the over heat cutout fuse tripping. Fuel delivery will cease and an “overheat shut down” follows.
- If at any time the voltage drops below 20V, or rises above 30V, a “high/low voltage” shutdown follows (after a 20 second delay).

6. Operational Flow Chart

		STARTING PHASE				RUNNING PHASE	SHUT DOWN PHASE	
Operating Mode		System Check	Optional Pre-heat	Purge	Ignition Attempt	Controlled Heating	Cool Down	Off or Stand by
Water Pump 		Off	On	On	On	On	On	Off On: if in stand by
Blower 		Off	Off	On	On	On	On	Off
Fuel pump Solenoid 		Off	Off	Off	On	On	Off	Off
Electrodes 		Off	Off	Off	On	Off	Off	Off
Nozzle Pre-heat (optional) 		Off	On	Off	Off	Off	Off	Off
Time 		1- 3 sec.	30 sec.	10 sec.	up to 10 sec.	Operation until switched off manually or automatically		approx. 3 min.

Note: During the controlled heating cycle, if the coolant temperature exceeds 176°F(80°C) the Burner will switch off. Burner will automatically restart once coolant temperature reaches 149°F(65°)



Wiring Diagram (with fuel nozzle preheat)

Model # CA 1869 25

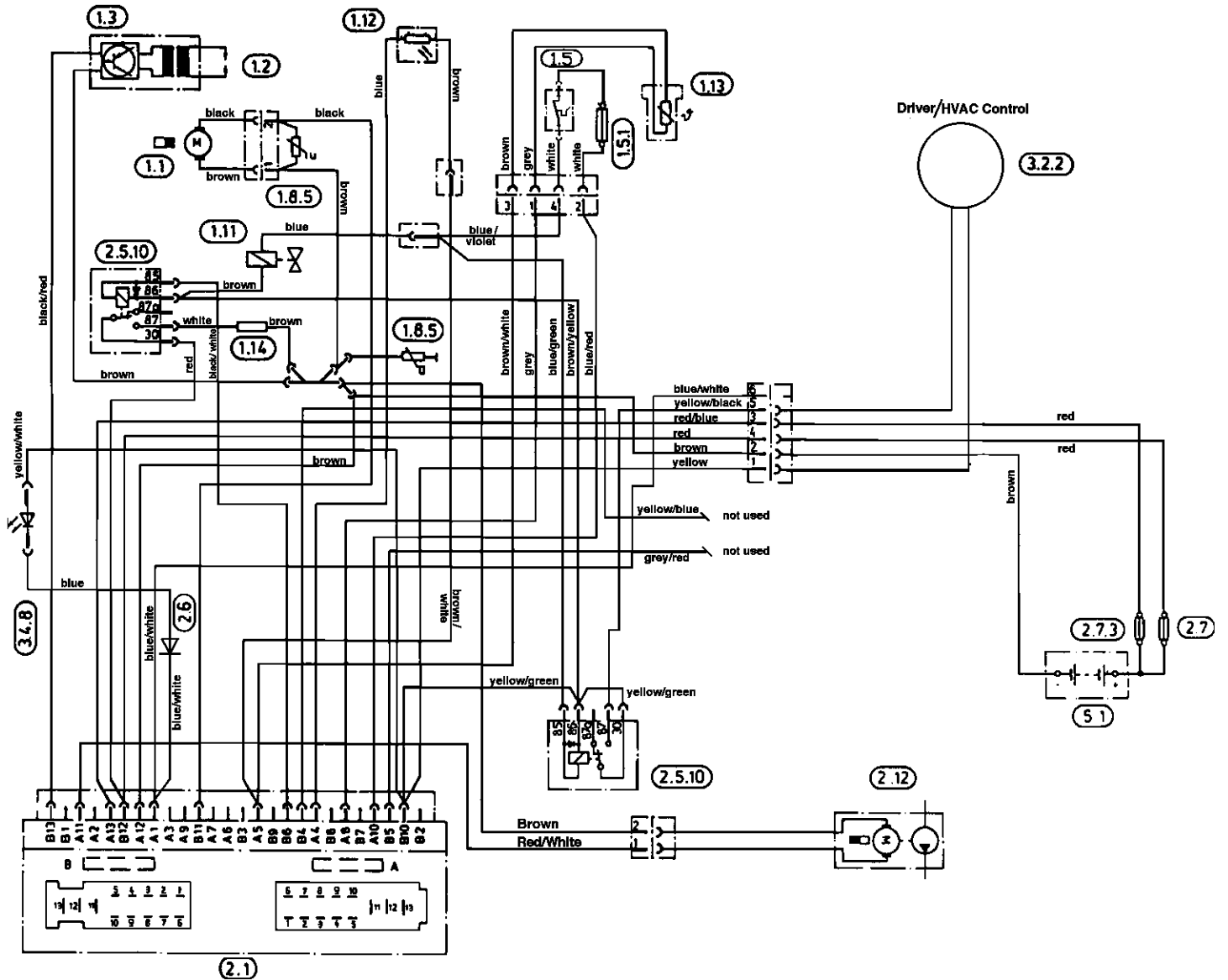

- | | | | |
|-------------------------------|------------------------------|------------------------------|-------------|
| 1.1 Burner motor | 1.11 Fuel solenoid valve | 2.6 Diode | 5.1 Battery |
| 1.2 Ignition electrodes | 1.12 Flame sensor | 2.7 Main fuse 25 amp | |
| 1.3 Ignition spark generator | 1.13 Temperature sensor | 2.7.3 Water pump fuse 10 amp | |
| 1.5 Overheat switch (stage 1) | 1.14 Fuel nozzle pre heat | 2.12 Water pump | |
| 1.5.1 Overheat fuse (stage 2) | 2.1 Control unit | 3.2.2 HVAC control | |
| 1.8.5 Varistor | 2.5.10 Relay, burner display | 3.4.8 Diagnostic light | |

IV. Maintenance Troubleshooting & Repairs

1. Recommended Periodic Maintenance

- Check coolant hoses, clamps, and make sure all valves are open. Maintain the engine manufacturers recommended coolant level and ensure that the heater is properly bled after service on or involving the coolant system.
- Visual check of all fuel lines for leaks. Check and if necessary replace fuel filter inserts.
- Check and if necessary replace gaskets on ignition electrodes.
- Visual check of electrical lines and connections for corrosion.
- Check and if necessary clean photoresistive cell.
- Run your heater at least once a month during the year (for a minimum of 15 minutes).
- Maintain your batteries and all electrical connections in good condition. With insufficient power the heater will not start. Low and high voltage cutouts will shut the heater down automatically.
- Use fuel suitable for the climate (see engine manufacturers recommendations). Blending used engine oil with diesel fuel is not permitted.

2. Troubleshooting

Basic Troubleshooting

In the event of failure there are several items which should be checked first before any major troubleshooting is done.

- Check
- Circuit breakers and Fuses.
 - Electrical lines and connections
 - For interference in Combustion air and Exhaust pipes.
 - That there is fuel in the tank.
 - Battery voltage
-
- If heater does not ignite - HVAC system might **not** be calling for heat. Shut bus off and use manual control to try heater.



Self Diagnostics Troubleshooting

The D24W heater is equipped with an automatic testing capability which can be used to check for faults. A built-in LED provides a full time diagnostics display. Signals, descriptions and remedies are provided on the next few pages.

An optional Fault Code retrieval device can provide a numeric fault code display. Match the numeric codes to the descriptions and remedies listed on the following pages to troubleshoot the heater.

Fault code retrieval device
P/N CA1 05 020

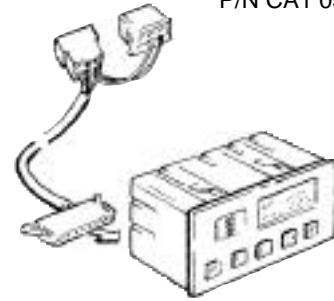





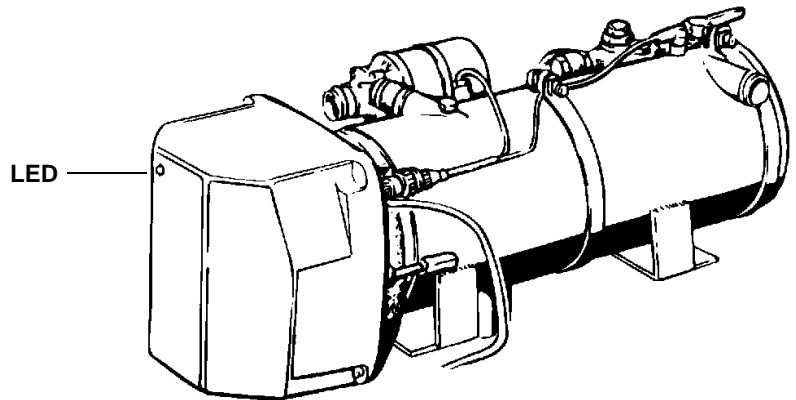





Built-in LED and Diagnostic display.

The LED indicator and fault code chart are located on the heater (front cover). Fault descriptions and remedies are found on the following pages.



DIAGNOSTIC SIGNALS

Table with diagnostic signals and their corresponding LED patterns. Signals include: NORMAL OPERATION, WARNING VOLTAGE - UNDER/OVER, PHOTORESISTIVE CELL DEFECTIVE, TOO MANY REPEATED STARTS, BURNER MOTOR DEFECTIVE, UNDER VOLTAGE, OVERVOLTAGE, NO START SAFETY TIME EXCEEDED, TEMPERATURE SENSOR, SOLENOID VALVE SHORT CIRCUIT, IGNITION ELECTRODES OR CONNECTION ERROR, CONTROL UNIT DEFECTIVE, WATER PUMP DEFECTIVE, OVERHEATING OR CONNECTION AT SOLENOID VALVE. Includes a legend for signal durations: 1.6 SECONDS and 0.3 SECONDS.

Fault Code	Fault description	Indication		Remedy
		Fault signal/flashing code		
000	No fault			
001	Pre-heating, overvoltage			Check control unit. Charge battery
002	Pre-heating, under voltage			Charge battery.
010	Overvoltage switch-off			Check control unit. Check battery charge. Connect heater directly to the battery.
011	Under voltage switch-off			Charge battery. Check control unit. Check cross sections of power leads.
012	Overheating			Check electric lines, connections and function of safety thermal cutout fuse and relay burner display; check water flow; check water pump and if necessary replace; check leads and connections to fuel solenoid.
025	Short circuit at diagnostic output	No flashing code		Check diagnosis lead. No power to unit, check fuses. Check connection to control unit.
032 033	Burner motor			Check combustion air fan. Replace if necessary. Check motor and connections to motor-power consumption approx. 140W, speed 3000-3250 rpm. Check connections to control unit.
047	Short circuit at fuel solenoid valve or relay coil at burner			Check electrical lines and connections to control unit. Check solenoid valve and burner relay.
051	Photoresistor defect			Check flame monitor-bright <30kΩ, dark >100kΩ Clean photoresistor or replace.
052	Failure to start/safety time expired			No flame was detected during the start up phase . Check the fuel supply & wiring to solenoid Check exhaust & combustion air piping. Check and if necessary replace ignition spark generator and relay for ignition generator; check and if necessary replace ignition electrodes; clean photoresistor. continued....

Fault Code	Fault description	Indication		Remedy
		Fault signal/flashing code		
053	Flame goes out during operation/Too many repeated starts	■ ■		Heater has started (flame detected) and indicates flame loss in power setting. Check fuel flow rate, blower speed (3000-3650rpm), fuel supply, exhaust pipe and combustion air piping. If combustion is O.K, check photoresistor, replace if necessary.
059	Water temperature rises too quickly	■ ■ ■ ■ ■ ■ ■ ■		Check water circulation and temperature control sensor. Check water pump
060	Interruption in temperature sensor	■ ■ ■ ■ ■ ■ ■ ■		Measured temperature lies outside measuring range. Check sensor. Check connections to temperature probe, connections to control unit, check plug type connections at relay. Test values-20°C=2000Ω, 65°C=2700Ω
061	Short circuit in temperature sensor	■ ■ ■ ■ ■ ■ ■ ■		Measured temperature lies outside measuring range. Check sensor. Check connections to control unit
064	Interruption in flame sensor		No flashing code	
065	Short circuit in temperature sensor			
090	Control unit faulty			
092				
093				
094				
095				
096				
097	Control unit defect or cable harness fault	■ ■ ■ ■ ■ ■ ■ ■		Replace control unit. Check and if necessary replace control unit. Check cable harness.
091	External interference voltage	■ ■ ■ ■ ■ ■ ■ ■		Check voltage supply. Check connection to control unit

Troubleshooting without diagnostic system

Fault →

Cause ↓

	Fan does not start					Heater does not ignite, cuts out automatically					Heater gives off soot					Heater ignites and cuts out automatically					Heater switched off by safety thermal cutout or temperature probe					Heater smokes during starting and delayed shutoff					Heater causes mechanical noises or motor speed to low					Check	Remedy
Safety thermal cutout switch has triggered																																				Check switch off heater, check water flow' D24W=2000l/h, D30W=2500l/h Max. temperature difference between water inlet and water outlet at heater approx. 10°C	Bleed water circulation system,check for proper flow; Check safety thermal cutout fuse
Safety thermal cutout switch faulty																																				Visual check/continuity check	Replace safety thermal cutout switch
Temperature probe faulty																																				Visual Check/continuity check 20°C=2000 ohms, 65°C=2700 ohms	Replace temperature probe
Control unit faulty																																				No positive applied to electric motor, if so no positive applied to solenoid valve	Replace control unit
Electric motor faulty																																				Is positive applied to electric motor? If so.....	Replace electric motor
Ignition spark generator faulty																																				Is positive applied to ignition spark generator?....No positive applied to ignition spark generator?....	If so-replace ignition spark generator Replace control unit
Mixing head coked																																				Visual check	Clean mixing head
Ignition electrodes faulty																																				Visual check; check electrode gap	Replace electrodes and adjust gap
Lack of fuel																																				Visual check of fuel lines and connections	Repair fuel lines and connections
Fuel pump sluggish, faulty																																				Visual check/functional check fuel return line constricted	Replace fuel pump, repair fuel line
Fuel nozzle clogged, bad (sometimes excess fuel)																																				Visual check	Replace atomizer nozzle
Solenoid valve does not open																																				Functional test	Replace fuel pump
Too much fuel being pumped																																				Fuel line constricted, measure fuel quantity	Repair fuel return line; adjust fuel quantity
Too little combustion air																																				Measure CO ₂ (24V: approx. 10.5%); Measure motor speed (3000-3650rpm; power consumption approx.140W); Air intake or exhaust pipe blocked, fan gap too wide	Adjust combustion air, replace electric motor, remove blockage, adjust fan gap
Gaskets on flame monitor, ignition electrodes, burner and heat exchanger leaking																																				Visual check	Tighten nuts and bolts, replace gaskets if necessary, press down lock washers of ignition electrodes
Photoresistive cell faulty																																				Visual check/functional check (bright <30k ohms, dark > 100k ohms)	Clean flame probe, replace if necessary
Water pump faulty, too little water being pumped																																				Temperature difference water inlet and water outlet at heater > 10°C, water circulation system closed	Replace water pump, check water circulation system valves
Ball bearing of electric motor faulty																																				_____	Replace electric motor
Combustion air impeller catching																																				_____	Adjust gap between combustion air and burner casing
Solenoid valve not tight																																				Functional test	Replace fuel pump
Coupling half faulty																																				Visual check	Replace coupling half



3. Fuel Quantity Test

The fuel Quantity should be tested if the heater has difficulty starting or maintaining a flame.

Note: Measure the fuel quantity when the battery is sufficiently charged. At least 22V and at most 26V should be applied at the control unit during measurement.

A.Preparation

- Apparatus:- measuring glass, stop watch, \varnothing 6mm hose.
- Close shut off valve at fuel pump.
- Switch on heater and run until remaining fuel has been consumed.
- Disconnect fuel supply and return lines from heater
- Connect fuel hose to heater and bleed pipe as shown.
- Place pipe into measuring glass with fuel.
- Start heater briefly to fill fuel lines.
- Switch on heater and measure withdrawal time for 50cm³.
- Compare measurement with figures in following table, adjust fuel quantity if necessary.

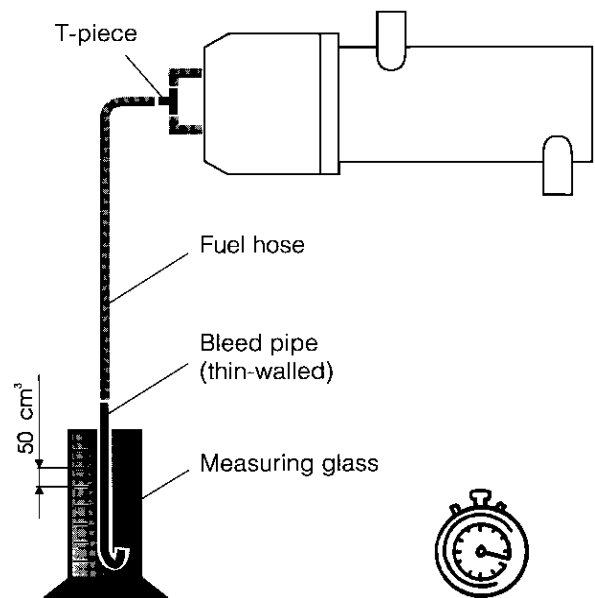

	Fuel consumption at rated voltage 24V	With drawl time for 50cm ³
D 24 W	2,90 l/hr	62 sec. +3

Adjusting the fuel quantity

If the fuel quantity is too high (withdrawal time too short), release locknut and reduce fuel quantity by turning adjusting screw anti clockwise.

If the fuel quantity is too low (withdrawal time too short), release locknut and increase fuel quantity by turning adjusting screw a clockwise.

1. Adjusting screw

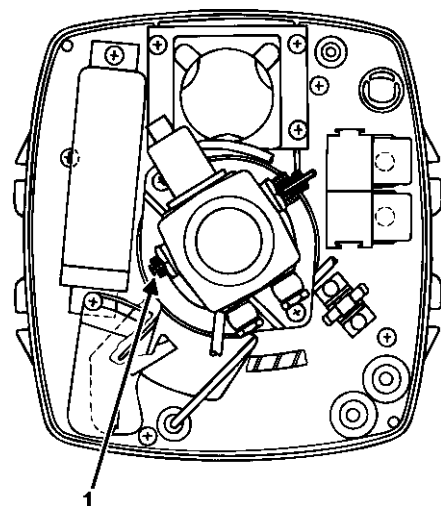

4. Adjusting combustion air

Measuring the CO₂ content

The combustion air quantity is determined by the CO₂ content depending on the voltage. To perform a correct measurement of the CO₂ content in the exhaust the heater must have reached its operating temperature and the fuel quantity must be within the permitted tolerances.

- Measure voltage at the heater
- Measure CO₂ content with a CO₂ indicator, pay attention to the manufacturer's instructions.
- Transfer both figures to the graph. If the point of intersection is outside the hatched area the combustion air gap has to be adjusted.

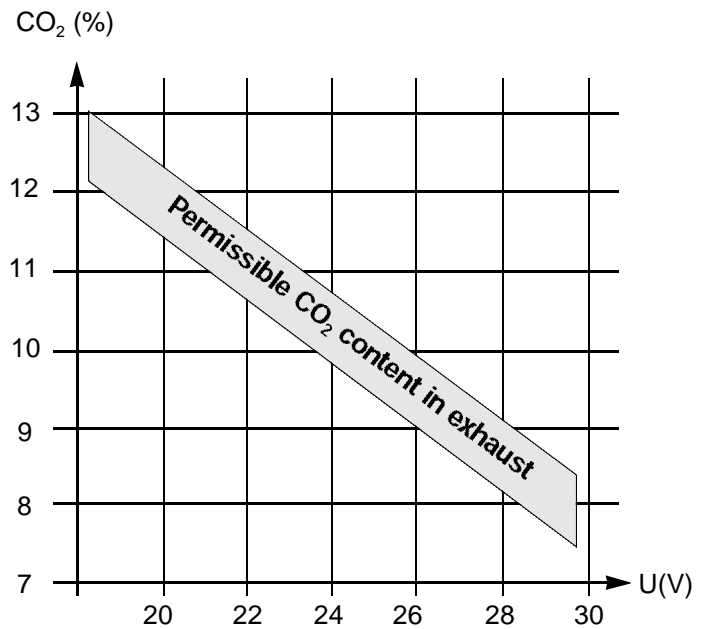

Adjusting the combustion gap

Adjusting fastening screws.

If the CO₂ content is below the figures in the graph reduce the combustion air gap by moving the air baffle plate.

If the CO₂ content is above the figures in the graph increase the combustion air gap by moving the air baffle plate.

- 1 Fastening screw
- 2 Air baffle plate
- 3 Combustion air gap

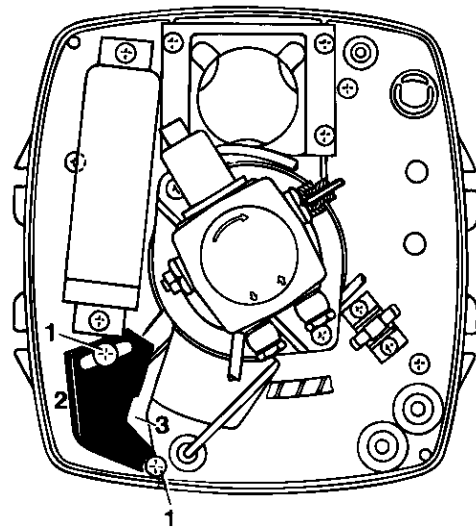

5. Dismantling water pump

- Remove screws from pump housing and remove intake flange
- Unscrew locking nut and remove impeller
- Remove axial face seal and thrust washer from monitor shaft
- Remove screws in pump flange and remove pump flange.
- Replace faulty parts.

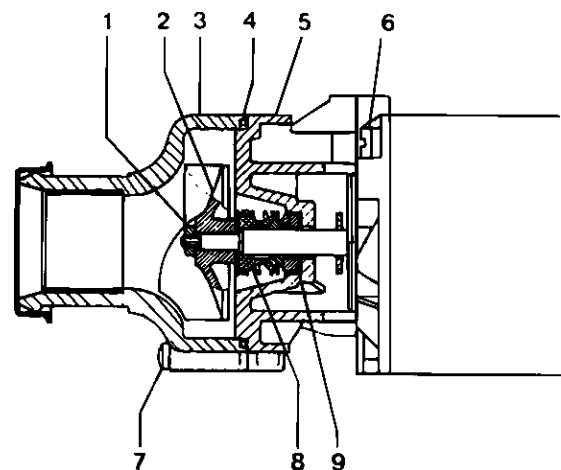

- | | | |
|---------------------|-----------------|---------------------|
| 1 Locking nut | 2 Impeller | 3 Pump housing |
| 4 O-ring | 5 Pump Flange | 6 Screw-pump flange |
| 7 Screw-pump casing | 8 Thrust washer | 9 Axial face seal |

Note: Clean axial face seal and thrust washer before assembly with a dry cloth. Contact faces must be free of grease and dust. Always replace O-ring.



6. Repairs

Removing the safety cap

Release both locking screws on the safety cap.
Remove safety cap

- 1 Locking screw

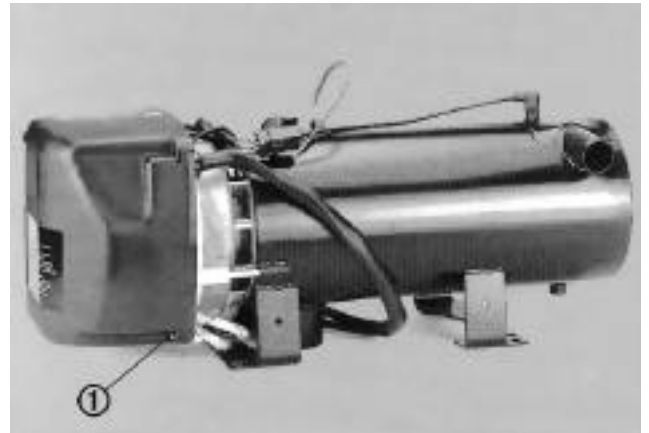

Removing the control unit

Remove safety cap.
Disconnect plugs from control unit.
remove control unit from holder.

Removing ignition spark generator

Remove safety cap
Disconnect both plug caps from ignition electrodes.
Disconnect electric plugs from control unit and unclip the black/red cable from the control unit casing.
Release locking screws from ignition spark generator.
Remove ignition spark generator and pull the two high voltage cables through the rubber grommets in the casing flange

- 1 Control unit
- 2 Holder for control unit
- 3 Ignition spark generator

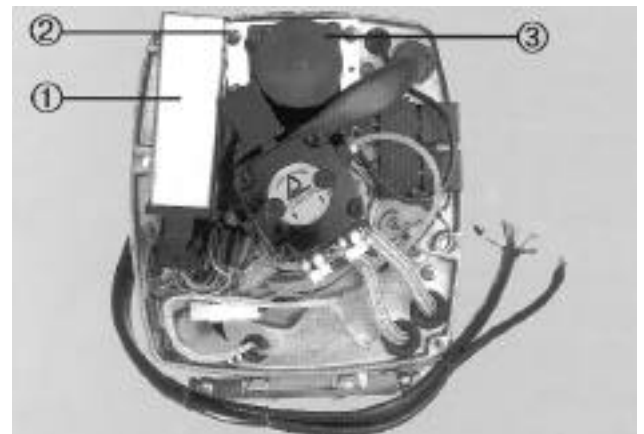

Removing burner

Remove safety cap.
Disconnect cable loom-safety thermal cutout fuse and cable loom-temperature probe.
Release two allen key bolts from burner.
Unscrew and remove burner from mounting.

Check gaskets for damages, replace if necessary .
Insert burner with holder into mounting.
Tighten both Allen key bolts alternatively.
Connect cable loom-safety thermal cutout fuse and cable loom-temperature probe.
Replace safety cap.

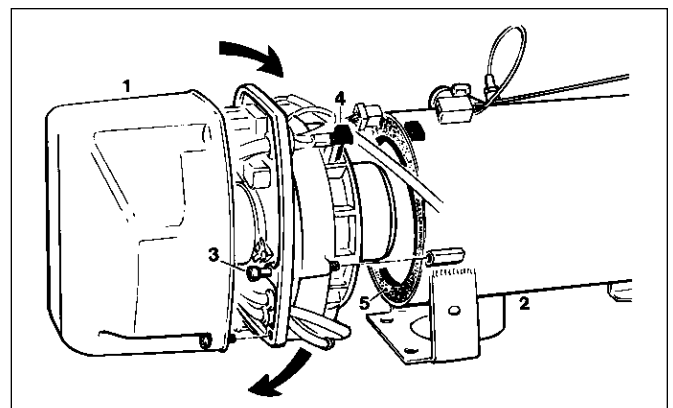

- | | |
|------------------|----------|
| 1 Burner | 4 Holder |
| 2 Heat Exchanger | 5 Gasket |
| 3 Locking screw | |

Removing fuel nozzle and ignition electrodes

Removing mixing head

Remove safety cap. Remove burner
Release both locking screws from mixing head and remove mixing head.

- 1 Mixing head



Removing ignition electrodes

Disconnect plug from ignition electrodes.
Loosen electrode holder and remove ignition electrodes.

Removing fuel nozzle

Unscrew fuel nozzle, collect the remaining fuel in a container

- 1 Ignition electrodes
- 2 Fuel nozzle
- 3 Fuel nozzle pre-heater

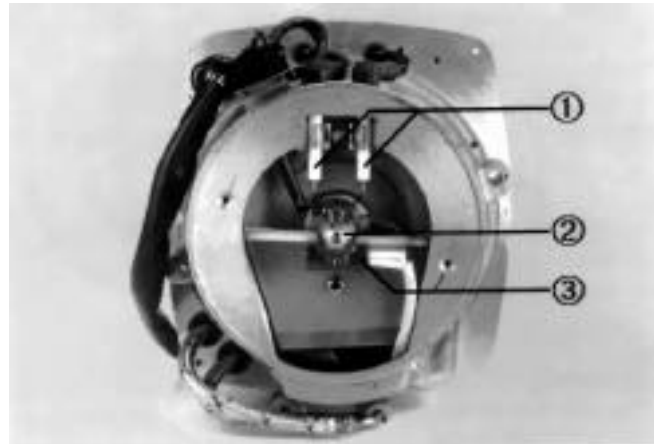

Adjusting the ignition electrode gap

The safety cap contains a setting gauge to adjust the ignition electrodes.
This is mounted on the nozzle holder with side A or B upwards, depending on the heater model. MCI standard is side B.
Release ignition electrode holder. Press setting gauge against the fuel nozzle and align the ignition electrodes so that the electrode tips rest against the two front corners of the setting gauge.
Place gasket and locking washer on electrodes and press against the casing with a pipe or spanner.
Connect ignition cable plug caps to electrodes.
Fasten mixing head.
Insert burner into holder and fasten in place.
Check CO₂ content in exhaust (Ref. pg.20).

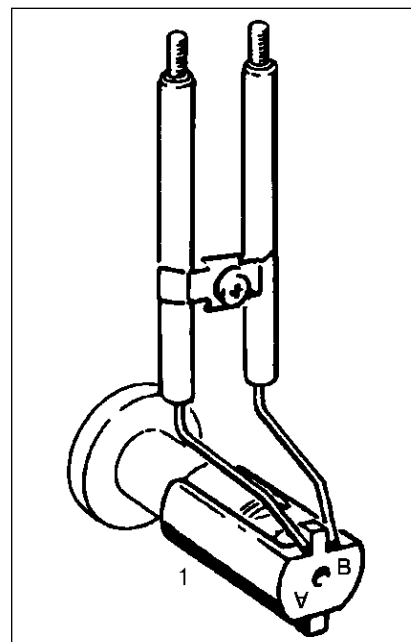



Removing the fuel pump

Remove safety cap. Remove control unit
 Mark the installation position of the fuel pump on the motor flange.
 Unscrew fuel lines from fuel pump.
 Disconnect solenoid valve cable from cable loom.
 Release the 3 Allen screws in the motor flange and remove fuel pump and coupling centre.
 Remove coupling half from fuel pump.

Replacing fuel pump

Mount coupling half on fuel pump.
 Insert coupling centre in the coupling half of the electric motor and insert fuel pump.
 Fasten fuel pump in motor flange with 3 Allen screws.
 Connect cable loom from solenoid valve.
 Connect fuel lines to fuel pump.
 Install control unit. Following installation check the fuel quantity and CO₂ content in exhaust. (Ref. pg.20)

- 1 Fuel pump
- 2 Allen screws
- 3 Fuel lines

Note: Note marking on the motor flange when fitting the fuel pump.

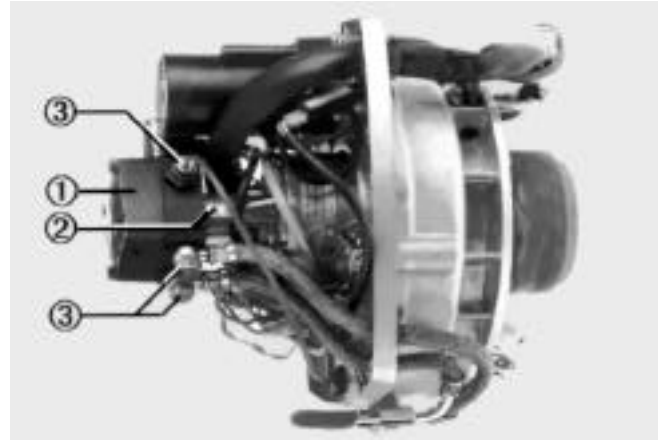

Removing the flame monitor

Release holder for flame monitor.
 Remove flame monitor from burner casing.
 Check optical part of the flame monitor: If the luminous intensity changes the resistance value has to be changed considerably.
 bright <30k ohms Dark >100k ohms
 If the values are not reached replace the flame monitor.
 Check cable for continuity.

When reinstalling the flame monitor the nose on the flame monitor must be inserted into the casing groove and the optical part pointing towards the burner chamber.

- 1 Flame monitor

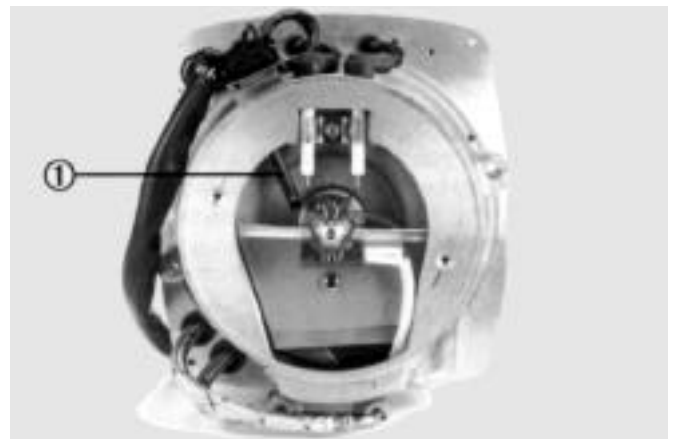

Removing the electric motor

Remove safety cap. Remove flame monitor.
 Disconnect plug caps from ignition electrodes.
 Remove control unit.
 Remove fuel pump (loosen Allen screws on periphery and lay fuel pump carefully on one side).
 Unclip electric motor's black cable from control unit's plug, disconnect the brown cable from the electric motor at ground.
 Unscrew 4 locking screws from flange and remove flange from casing.
 Release fixing screws from impeller (tool: 2.5 Allen key, 1=115mm) and remove impeller from motor shaft.

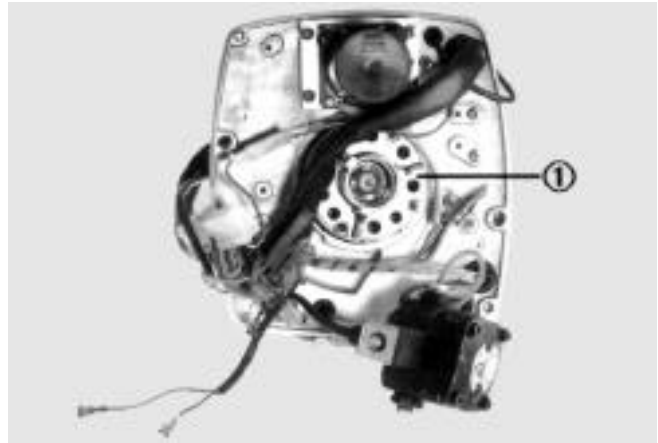

1 Locking screws

Unscrew 3 fixing screws from electric motor and remove electric motor from flange. Remove coupling half-section from electric motor.

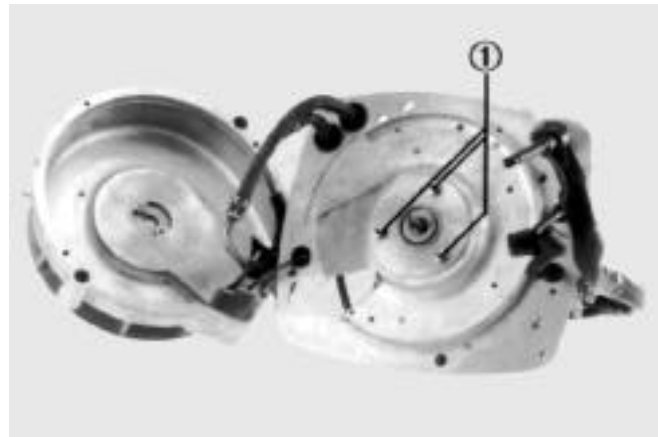

Mounting impeller

Adjusting the axial play

Mount impeller on motor shaft.
 Measure an axial gap of 0.4 mm (0.016") with a feeler gauge or a paper strip of corresponding thickness - as shown in corresponding diagram - adjust if necessary by moving the impeller.
 Tighten the impeller's fixing screw and check for free running.

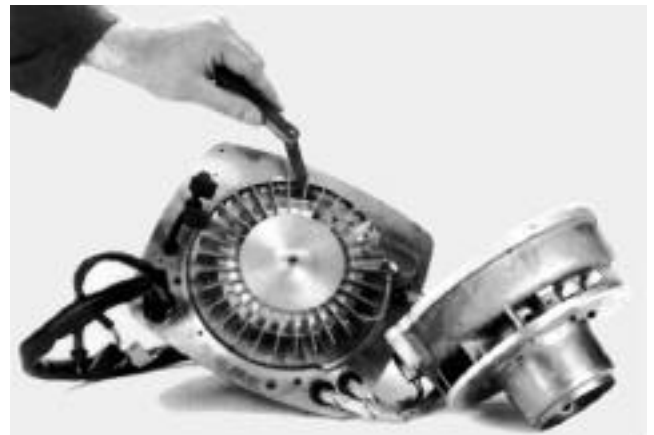

Adjusting the radial play

Fasten the casing flange to the casing so that both parts can be moved in relation to one another.
 Measure a radial gap of 0.4mm (0.016") between the impeller and casing with a feeler gauge through the combustion air opening on the underside of the casing. Adjust if necessary by moving the casing flange against the casing. Tighten fastening screws and check impeller for free running.

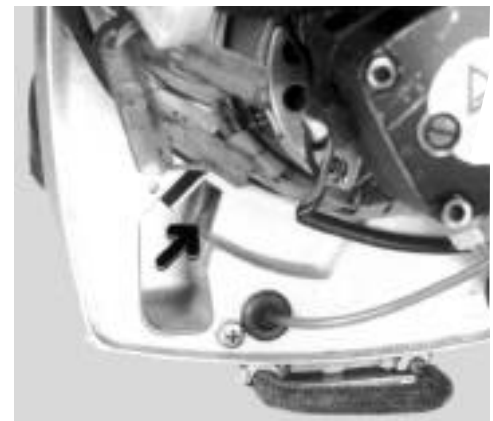
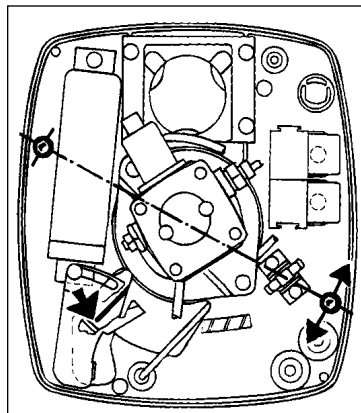

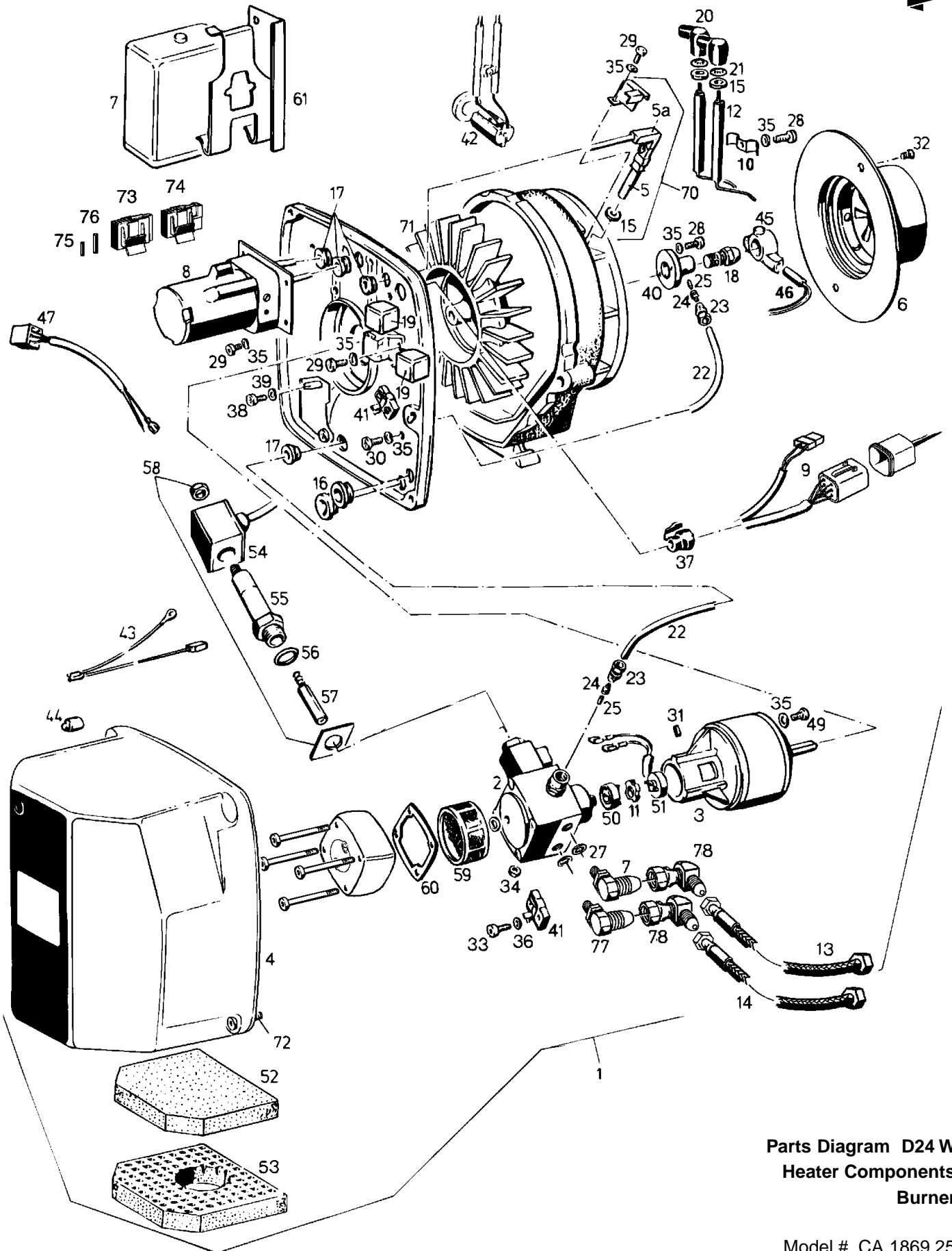

Parts Diagram D24 W
Heater Components
Burner

Description & Part #'s			D 24 W	CA 1869 25
Ref. No.	Description	Part Number		
1	Burner	25 1869 15 00 00 25 1870 15 00 00		•
2	Fuel pump	25 1869 99 46 00		•
3	Electric motor	25 1869 99 15 03		•
4	Protective cover assembly	25 1779 15 06 00		•
5	Photoresistive cell	25 1855 99 15 09		•
5a	Cable	25 1855 15 08 00		•
6	Mixing head	25 1604 15 01 00		•
7	Control unit (with nozzle preheat)	25 1733 50 00 15		•
8	Ignition spark generator	25 1869 99 56 00		•
9	Cable Harness assembly	CA1 00 108		•
10	Holder	25 1371 15 00 04		•
11	Coupling center part	25 1371 15 00 09		•
12	Ignition electrode	25 1595 15 00 05		•
13	Fuel return line	CA0 12 079-004		•
14	Fuel supply line	CA0 120 79-003		•
15	Sealing ring	25 1371 15 00 12		•
16	Grommet	25 1371 15 00 14		•
17	Shock mount	25 1371 15 00 15		•
18	Fuel atomizer nozzle	330 00 033		•
19	Relay	203 00 066		•
20	Ignition line protector	206 00 150		•
21	Lockwasher	171 22 140		•
22	Internal fuel line	090 31 117		•
23	Nipple	263 10 010		•
24	Clamping ring	263 35 030		•
25	Supporting sleeve	132 35 014		•
26	Hollow screw	104 10 020		•
27	Copper washers	323 16 014		•
28	Allen head-screw	CA3 00 130		•
29	Philip head screw	103 10 318		•
31	Allen head set screw	Hardware		•
32	Counter sunk screw M5x8 DIN	Hardware		•
33	Allen head cap screw	Hardware		•
34	Hexagon nut M6DIN	CA3 00 209		•
36	Spring washer 4mm	CA3 00 313		•
37	Strain relief grommet	320 31 061		•
38	Fillisterhead bolt M4x6 DIN	Hardware		•
39	Washer	CA3 00 331		•
40	Nozzle holder	25 1436 15 00 03		•
41	Plug socket connection	25 1578 15 00 08		•
42	Setting gauge	25 1578 15 00 10		•
43	Cable	25 1752 15 03 00		•



Ref. No.	Description	Part Number	D 24 W	CA 1869 25
44	LED indicator	201 00 056		•
45	Clamping piece (nozzle pre heat)	25 1371 89 16 00		•
46	Heat element (nozzle pre heat)	25 1371 89 15 02		•
47	Cable	25 1855 89 03 00		•
49	Fillister head bolt M5x10 DIN	Hardware		•
50	Coupling half	25 1371 15 01 01		•
51	Coupling half	25 1623 15 02 01		•
52	Upper damping plate	25 1371 15 06 03		•
53	Lower damping plate	25 1371 15 06 04		•
54	Solenoid coil	249 00 004		•
55	Armature	249 00 001		•
56	O-ring	249 00 003		•
57	Core	249 00 002		•
58	Hardware for solenoid	249 00 007		•
59	Filter	249 00 006		•
60	Cover seal	249 00 005		•
61	control box bracket	25 1779 15 05 00		•
70	Flame sensor	25 1855 99 15 09		•
71	Combustion air blower wheel	25 1623 15 01 00		•
72	Sloted panhead bolt	CA 300 139		•
73	Relay Socket	CA1 91 075		•
74	Relay Socket	CA1 91 076		•
75	Flat plug	206 00 201		•
76	Twin leaf-spring contact	206 00 200		•
77	90° elbow fuel connector	CA0 12 072		•
78	45° fuel fitting	CA0 12 073		•

Parts Diagram D24W
Heat Exchanger
 Models CA 1869 25

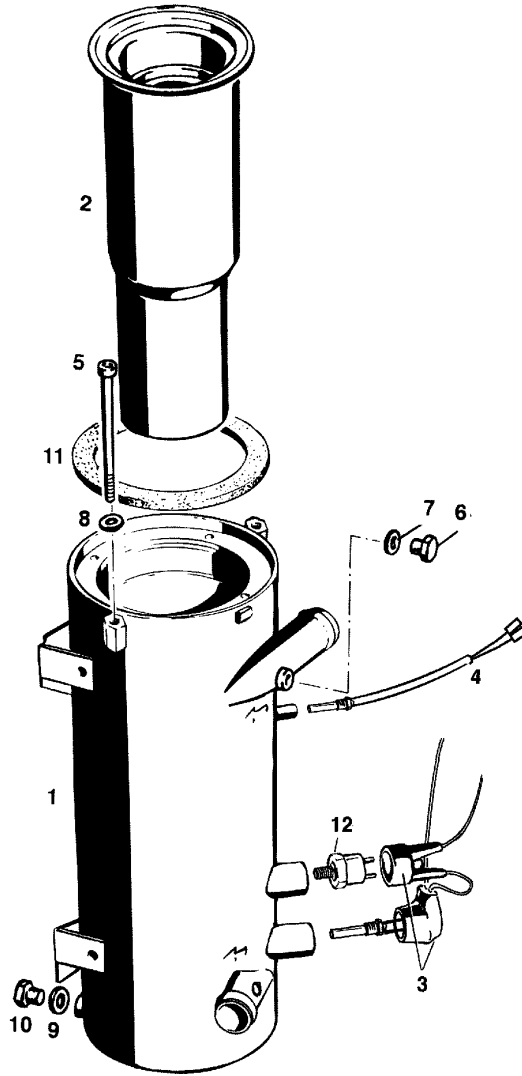

Deutch connectors

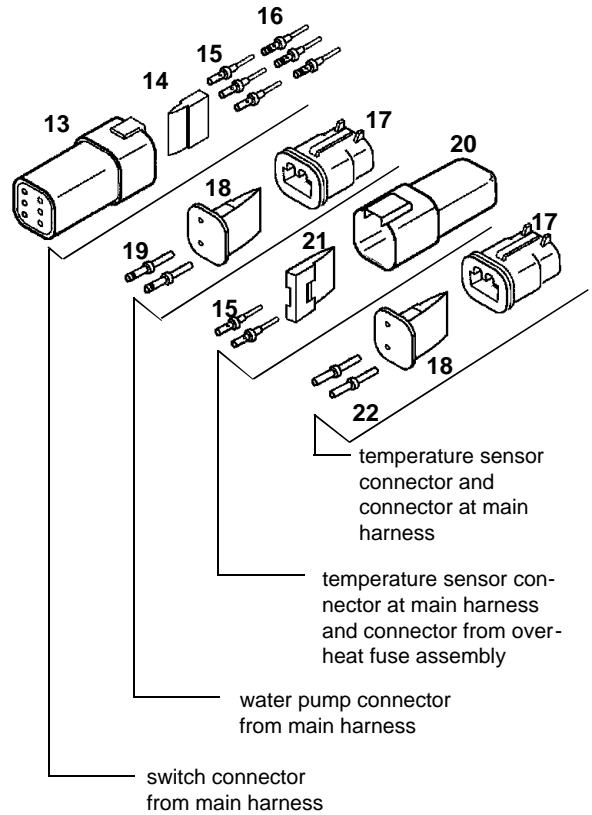

Ref. No.	Description	Part Number	D 24 W	CA 1869 25
1	Heat exchanger	25 1855 06 00 00	•	•
2	Flame tube	25 1669 57 00 00	•	•
3	Overheat fuse assembly	CA1 00 105	•	•
4	Temperature sensor assembly	CA1 00 107	•	•
5	Allen hd. cap-M8x120 DIN	100 10 012	•	•
6	Bleed screw	105 20 000	•	•
7	Sealing ring	324 97 043	•	•
8	Washer	120 10 083	•	•
9	Sealing ring	323 16 007	•	•
10	Drain Plug	105 10 015	•	•
11	Gasket	25 1371 01 00 02	•	•
12	Overheat protection switch	25 1436 01 00 03	•	•
13	Deutch connector (from main harness to switch)	CA1 91 071	•	•
14	Lock	CA1 91 073	•	•
15	Pins (3)	CA1 90 265	•	•
16	Pins (3)	CA1 90 263	•	•
17	Deutch connector (from main harness to water pump)	CA1 91 058	•	•
18	Lock	CA1 91 060	•	•
19	Pins (2)	CA1 90 266	•	•
20	Deutch connector (temperature connect at main harness)	CA1 91 057	•	•
21	Lock	CA1 91 059	•	•
22	Pins (2)	CA1 90 264	•	•

1st. Printing - August 1997

Printed in Canada

P/N: 610-111-0597-MCI

Espar Products, Inc.

6435 Kestrel Road
Mississauga, Ontario
Canada L5T 1Z8

17370 N. Laurel Park Drive
Suite 400E
Livonia, Michigan
United States
48152-3984

Canada (Tel): 905-670-0960

800-668-5676

Fax: 905-670-0728

U.S. (Tel): 800-387-4800

www.espar.com

inquiries@espar.com